

# Rinnai

## Portable Unflued Gas Convection Heater Operation Manual

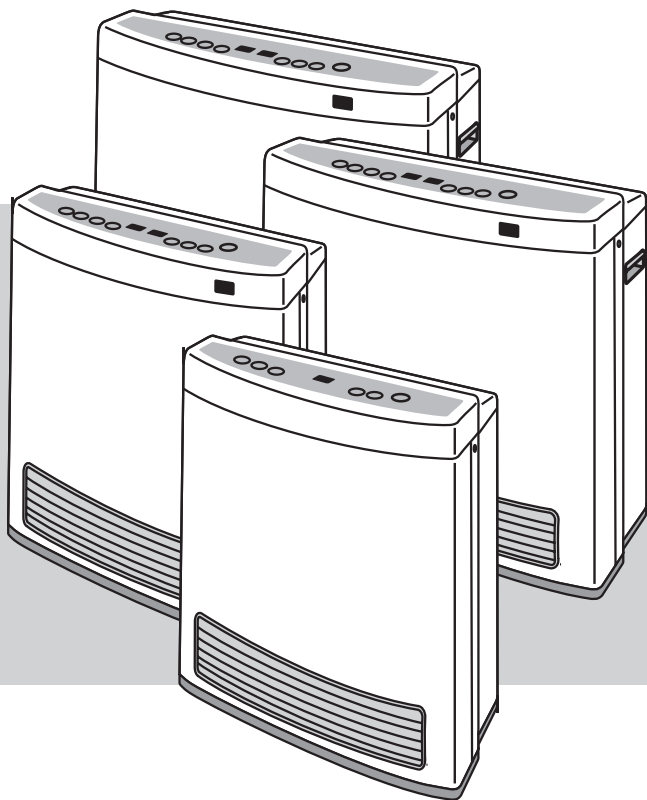

To Suit Models  
*Avenger 25*  
*Blaze 21*  
*Dynamo 15*  
*Enduro 13*

This appliance shall be installed in accordance with:

- Manufacturer's Installation Instructions
- Local Regulations and Municipal Building Codes

This appliance must be serviced and repaired by an Authorised Person.



The Australian  
Gas Association  
All Rinnai gas products  
are A.G.A. certified.



N10378

# TABLE OF CONTENTS

<b>REGULATORY INFORMATION</b> .....	<b>ii</b>
<b>WARRANTY</b> .....	<b>ii</b>
<b>ABOUT YOUR PORTABLE CONVECTOR HEATER</b> .....	<b>1</b>
GENERAL DESIGN LAYOUT .....	1
NAVIGATING THE CONTROL PANEL .....	2
NAVIGATING THE REMOTE CONTROL .....	3
<b>FEATURES</b> .....	<b>4</b>
<b>IMPORTANT POINTS</b> .....	<b>5</b>
<b>INSTALLATION</b> .....	<b>7</b>
UNPACKING THE APPLIANCE .....	7
WHAT'S IN THE BOX .....	7
BEFORE INSTALLING THE APPLIANCE .....	7
CHECKING ROOM SIZE .....	8
VENTILATION .....	8
GAS CONNECTION .....	8
<b>HOW TO OPERATE THE HEATER</b> .....	<b>9</b>
TO TURN THE HEATER ON .....	9
TO ADJUST SET TEMPERATURE .....	9
TO TURN THE HEATER OFF .....	10
USING THE ECONOMY MODE .....	10
<b>TIMER OPERATION - AVENGER, BLAZE &amp; DYNAMO</b> .....	<b>11</b>
CLOCK AND DUAL TIMERS .....	11
CHECKING THE CLOCK .....	11
SETTING THE CLOCK .....	11
PROGRAMMING TIMER 1 .....	11
PROGRAMMING TIMER 2 .....	12
OPERATING TIMERS .....	12
PREHEAT .....	13
USING THE OVERRIDE FUNCTION .....	13
<b>TIMER OPERATION - ENDURO</b> .....	<b>14</b>
OPERATING THE ON TIMER .....	14
OPERATING THE OFF TIMER .....	14
<b>LOCK AND SAFETY DEVICES</b> .....	<b>15</b>
USING THE LOCK FUNCTION .....	15
SAFETY DEVICES .....	15
<b>CARE AND MAINTENANCE</b> .....	<b>16</b>
AIR FILTERS .....	16
REMOVING FILTERS .....	16
SERVICE .....	16
TROUBLE SHOOTING CHECKLIST .....	17
ERROR CODES .....	17
<b>SPECIFICATIONS</b> .....	<b>18</b>
GENERAL SPECIFICATIONS .....	18
WEIGHT AND MEASURES .....	18
<b>CONTACT INFORMATION</b> .....	<b>21</b>

# REGULATORY INFORMATION

This Appliance must be installed correctly by an authorised person. The installation of gas and electricity must conform to local regulations.

The installation must also comply with the instructions supplied by Rinnai.

Your Rinnai Convecter space heater has been certified by the Australian Gas Association. The A.G.A. Certification Number is shown on Data plate.

Please keep this instruction booklet in a safe place for future reference.

# WARRANTY

## RINNAI BRINGS YOU PEACE OF MIND WITH A 2 YEAR MINIMUM WARRANTY

### Rinnai Two Year Warranty - Terms and Conditions

1. During the 24 month period from date of purchase and subject to clauses 2 and 3 below, Rinnai New Zealand Limited ("Rinnai") will, at its own discretion, either replace or repair any defective product at no charge to the customer.
2. This warranty covers manufacturing defects only. This warranty will not apply if (for example) the product has been improperly installed or is otherwise installed contrary to manufacturer's recommendations, has been damaged during or after installation, has not been operated in accordance with operating instructions, or has been subjected to damage or abuse beyond that expected from conditions of normal use.
3. Warranty claims may be invalid if not accompanied by details of the installing or supervising gas fitter's registration number and the gas fitting certification number.
4. This warranty commences from the date of purchase. Proof of purchase is required at the time of any warranty claim.
5. Servicing of the product is to be carried out by a Rinnai authorised service centre.

All Rinnai appliances meet or exceed the safety standards required by New Zealand gas and electrical regulations. Rinnai is constantly improving its products and as such specifications are subject to change or variation without notice.

For future reference please take a moment to complete the following information:

Your Retailer: \_\_\_\_\_

Name: \_\_\_\_\_

Installation Address: \_\_\_\_\_

Telephone No. \_\_\_\_\_

Date of Purchase: \_\_\_\_\_ / \_\_\_\_\_ / \_\_\_\_\_

# ABOUT YOUR PORTABLE CONVECTOR HEATER

## GENERAL DESIGN LAYOUT

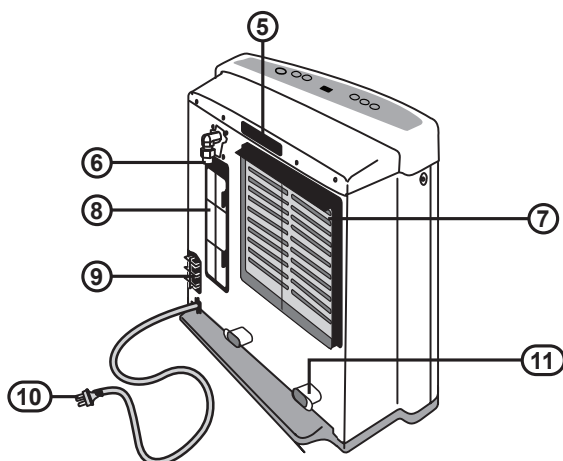
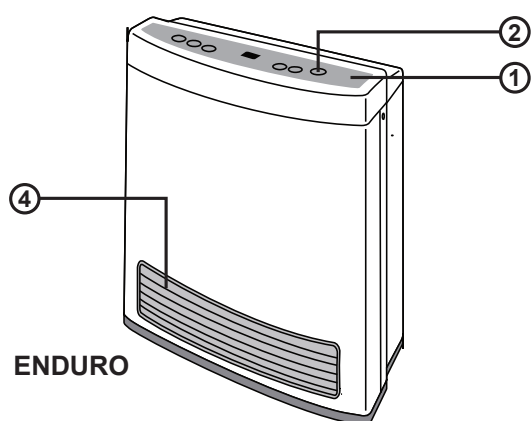
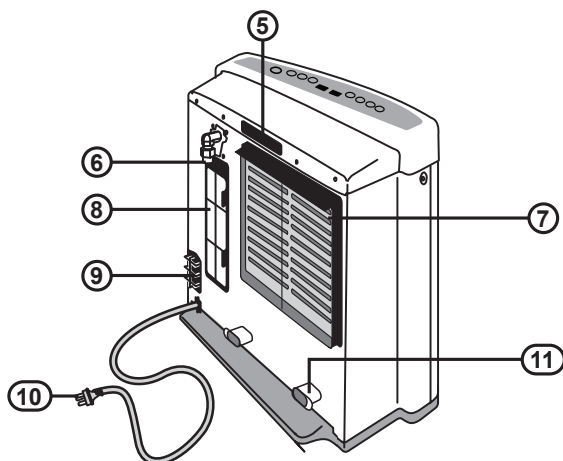
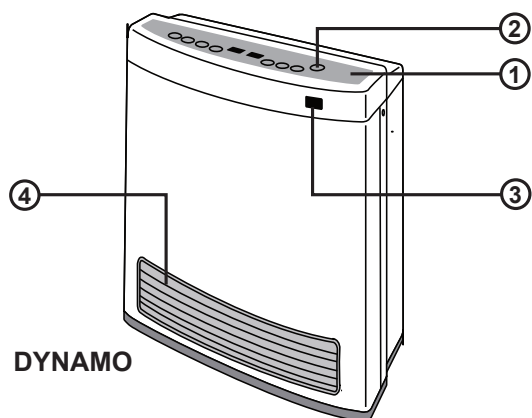
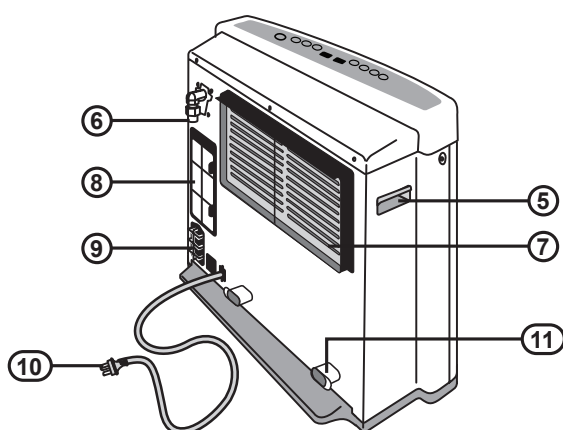
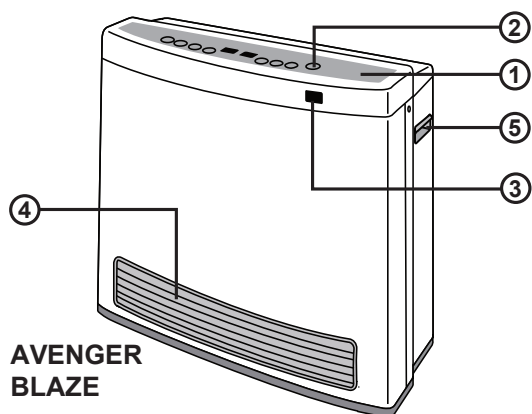

- ① Control panel
- ② ON / OFF button  
Stops and operates the heater.
- ③ Remote control receiver window
- ④ Louvre, warm air discharge
- ⑤ Carry handle(s)

- ⑥ Gas inlet connection
- ⑦ Filter 1
- ⑧ Filter 2
- ⑨ Thermistor
- ⑩ 240v power cord
- ⑪ Power cord tidy

# ABOUT YOUR PORTABLE CONVECTOR HEATER

## NAVIGATING THE CONTROL PANEL

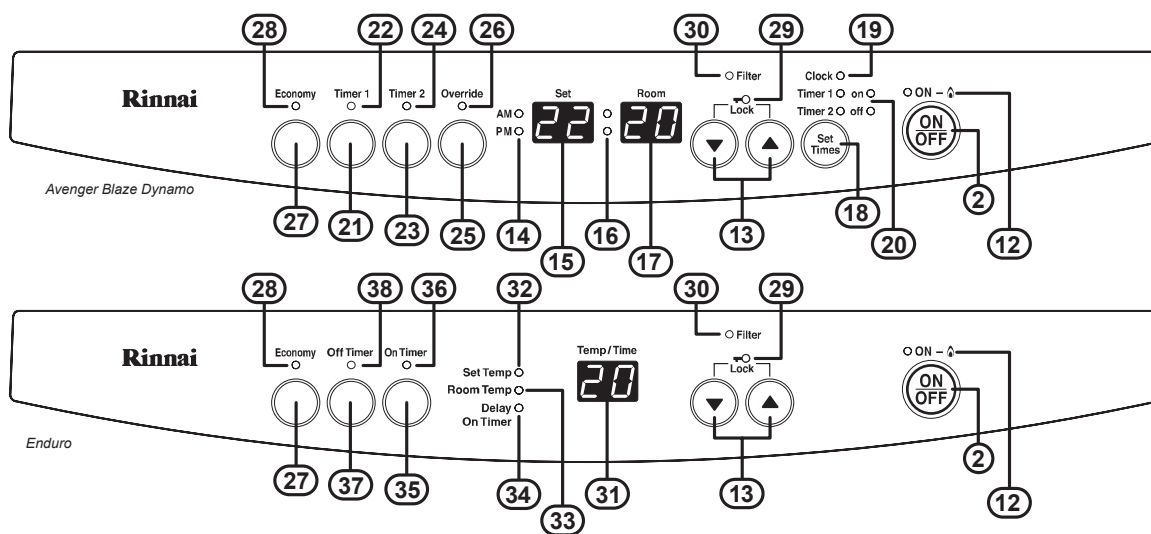

- ⑫ On / Combustion indicator**  
When GREEN appliance is in standby, when RED the burner is operating and when flashing RED there is a fault.
- ⑬ Up and Down buttons**  
Used to adjust set temperature, clock / timer settings and to operate the Lock function.
- ⑭ AM / PM indicators**  
Indicates AM / PM of clock / timers.
- ⑮ Digital (Set) display**  
Displays set temperature and hour digits for clock / timers.
- ⑯ Hour / Minute delineators**  
Delineates hours / minutes of clock / timers.
- ⑰ Digital (Room) display**  
Displays current room temperature, minute digits for clock / timers and error codes.
- ⑱ Set Times Button**  
Sets heater to adjust clock / timer functions.
- ⑲ Clock set indicator**  
Indicates heater is in clock setting mode.
- ⑳ Timer set indicators**  
Indicates heater is in timer setting mode.
- ㉑ Timer 1 button**  
Operates Timer programme 1.
- ㉒ Timer 1 indicator**  
Indicates Timer 1 is in operation.
- ㉓ Timer 2 button**  
Operates Timer programme 2.
- ㉔ Timer 2 indicator**  
Indicates Timer 2 is in operation.
- ㉕ Override button**  
Operates the manual Override function.
- ㉖ Override indicator**  
Indicates the Override function is in operation.
- ㉗ Economy button**  
Operates the Economy mode.
- ㉘ Economy indicator**  
Indicates Economy function is in operation.
- ㉙ Lock indicator**  
Indicates the Lock function is activated.
- ㉚ Filter indicator**  
Indicates that there is a filter blockage.
- ㉛ Digital (Temp / Time) display**  
Displays current room temperature (default), set temperature, Delay On Timer settings and error codes.
- ㉜ Digital Display Set Temp Indicator**  
Indicates that the Digital (Temp / Time) display ⑶⑴ is in the temperature setting mode.
- ㉝ Digital Display Room Temp indicator**  
Indicates that the Digital (Temp / Time) display ⑶⑴ is in room temperature mode.
- ㉞ Digital Display Delay On Timer indicator**  
Indicates that the Digital (Temp / Time) display ⑶⑴ is in the timer setting mode.
- ㉟ On Timer button**  
Sets and or operates the Delay On Timer.
- ㊱ On Timer indicator**  
Indicates heater is in Delay On Timer mode.
- ㊲ Off timer button**  
Operates the Off Timer (60 minutes).
- ㊳ Off timer indicator**  
Indicates heater is in Off Timer mode.

# ABOUT YOUR PORTABLE CONVECTOR HEATER

## NAVIGATING THE REMOTE CONTROL

- 39 ON button**  
Operates the heater.
- 40 OFF button**  
Stops the heater.
- 41 Up and Down buttons**  
Used to raise or lower the set temperature.
- 42 Infra red transmitter**  
Transmits signal to heater.
- 43 Battery**  
The remote control is powered by one CR2032 3V battery. To replace the battery simply slide open the battery cradle cover located on the back of the remote control. When installing a new battery ensure that the correct polarity (positive uppermost) is observed.

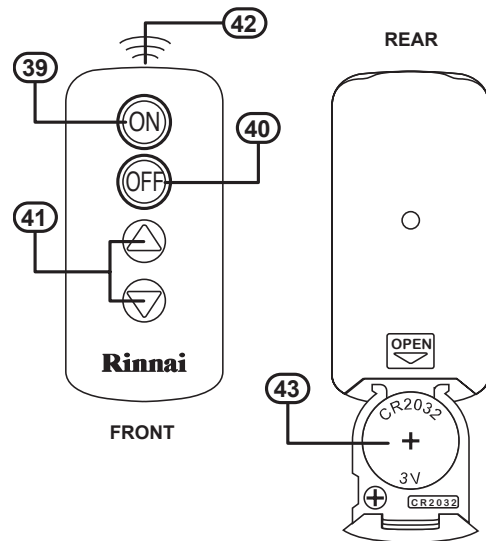

**ONLY use the specified CR2032 3V battery for the remote control**

**The remote control will not function if the heater is in Timer mode.**

**If the heater is operating in Override mode, using the STANDBY button will cancel any future timer operations, these will have to be reset manually.**

**Some fluorescent lights may interfere with the transmission of remote control signals, in this case changing the position from which you are operating the remote control may help.**

**Avoid leaving the remote control in direct sunlight and do not place the remote control close to the louvres of the heater.**

**Avoid getting the remote control wet, or dropping it.**

# FEATURES

## FEATURES COMMON TO ALL MODELS

<b>PUSH BUTTON IGNITION</b>	Only one touch of the ON/OFF button is required to operate the heater.
<b>CHILD LOCK</b>	When the Child Lock is activated all controls other than the ON/OFF button will be locked. Deactivating the lock releases the controls. If the lock is activated when the appliance is in STANDBY, all functions will be locked.
<b>FILTER INDICATOR</b>	When the fan filters become covered with dust, the filter indicator will flash. The filters should be vacuumed at regular intervals to optimise heating effectiveness.
<b>ECONOMY FUNCTION</b>	The Economy (ECON) function is an energy saving feature designed to control the room temperature and prevent discomfort from overheating.

## FEATURES OF AVENGER, BLAZE AND DYNAMO HEATER MODELS

<b>REMOTE CONTROL</b>	For the convenience of operating the heater between STANDBY or ON, as well as adjusting the temperature up or down while at a short distance from the heater.
<b>PRE-HEAT</b>	This function will automatically operate the appliance before the programmed start time of the Timer, in order to heat a room to the pre-set temperature by the programmed start time.
<b>MEMORY</b>	The micro-computer records selected preset temperatures, the times programmed into Timers as well as operating the Economy and Pre-heat modes, to maintain comfort levels.
<b>DUAL TIMERS</b>	<p>The Dual Timers allows you to program the appliance to come on for two separate periods each day, one period in the morning and one period in the evening. The built in Pre-heat Mode brings the room temperature to the temperature you have selected, by the time programmed into the Timer.</p> <p>The Dual Timer feature means that you can "Set and Forget" your heater. It will turn itself ON or to STANDBY at the times you have programmed until you cancel the Timer program.</p>

## FEATURES OF THE ENDURO HEATER MODEL

<b>MEMORY</b>	The micro-computer records selected preset temperatures, the time programmed into the On Timer as well as operating the Economy modes, to maintain comfort levels.
<b>DELAY ON TIMER</b>	<p>The On Timer allows you to program the heater to come on after a delayed period. This is a particularly useful feature to use overnight for automatic heating in the morning.</p> <p>The appliance begins heating a room once it has reached the end of the delay period selected.</p> <p>The heater will automatically come on and will continue to operate for a period of 60 minutes then automatically turn off.</p>
<b>OFF TIMER</b>	This feature allows you to program the heater to operate for a period of one hour before it automatically turns off.

# IMPORTANT POINTS

The appliance is not intended for use by young children or infirm persons without supervision.

Young children should always be supervised to ensure that they DO NOT play with the appliance.

DO NOT allow children or elderly persons to sleep in the warm air discharge from the heater.

DO NOT sit on this heater.

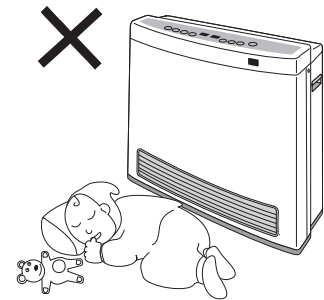
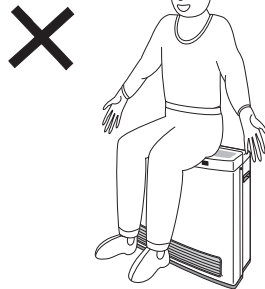
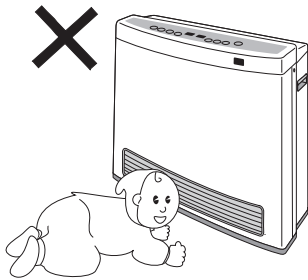

DO NOT post or allow children to post articles into the louvres of the heater.

DO NOT cover or place articles on this heater.

DO NOT place articles in front of the louvres.

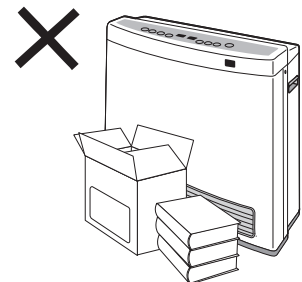
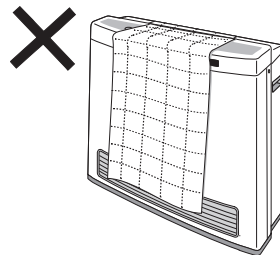
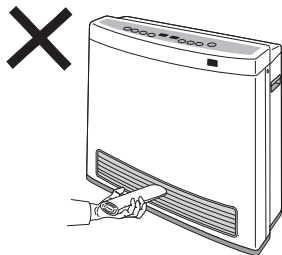

DO NOT operate / install this heater in areas where painting is taking place, or in places such as hairdressing salons, where there may be fluff and dust, and where aerosols are used.

Keep heater away from flammable materials. Combustible materials must not be placed where the heater could ignite them.

DO NOT spray aerosols near this heater while it is in use. Most aerosols contain butane gas which can be a fire hazard if used near this heater when it is in use.

Use of aerosols, paint, polishes etc. whilst this heater is in use may also cause unpleasant smells.

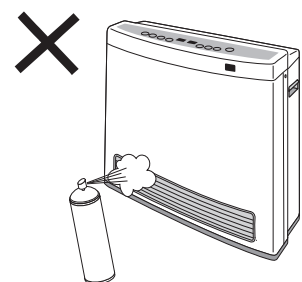
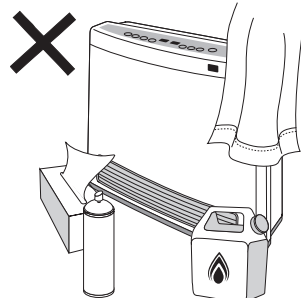
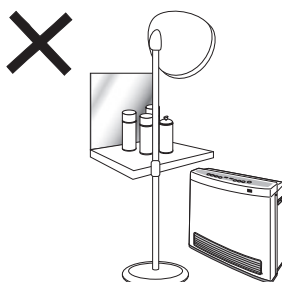



# IMPORTANT POINTS

It is recommended that a dedicated 240V 10 Amp power point be used with this appliance. DO NOT use power boards or double adaptors to operate this appliance. Heater MUST NOT be located below a power socket-outlet

DO NOT place containers of liquid on top of the heater. Water spillage can cause extensive damage to the appliance and create an electrocution hazard.

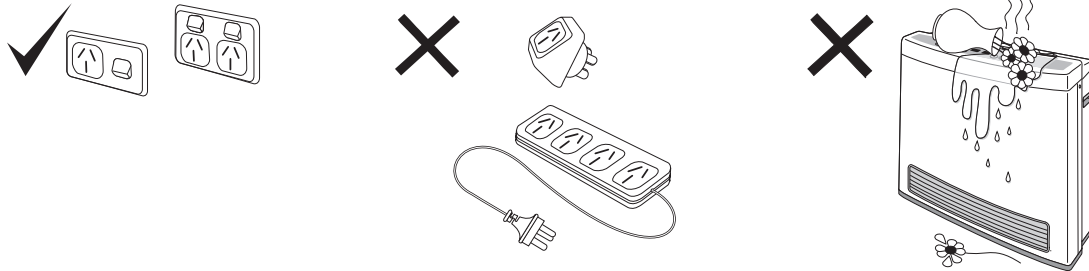

**When the heater is unplugged for an extended period the clock will stop and will need to be reset. However programmed ON/OFF times will remain in the memory.**

Turn the heater OFF after use. DO NOT unplug the heater while it is in operation or while the fans are still cycling. DO NOT move the heater while it is in operation or while the fans are still cycling.

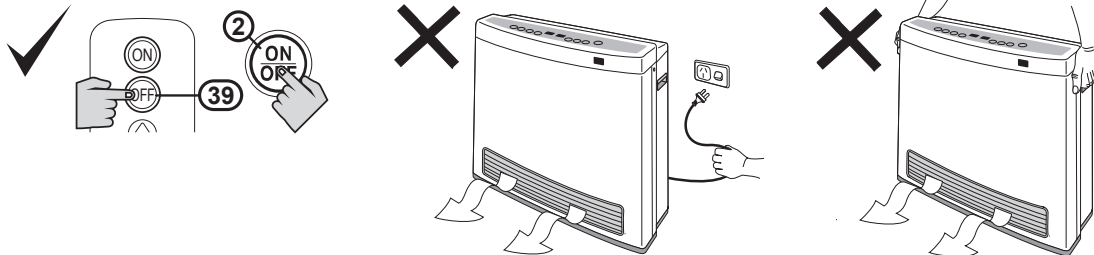

To prevent discolouration of floor coverings from heat, it is recommended that a mat be placed in front of the heater when it is in operation.

When the heater is operated for the first time or after long periods of non use a slight odour may be emitted, this is normal. However if odours persist switch off the appliance and contact Rinnai.

During peak operating periods the filters should be cleaned weekly, however if the Filter warning indicator illuminates, turn off the appliance immediately and clean filters before further use.

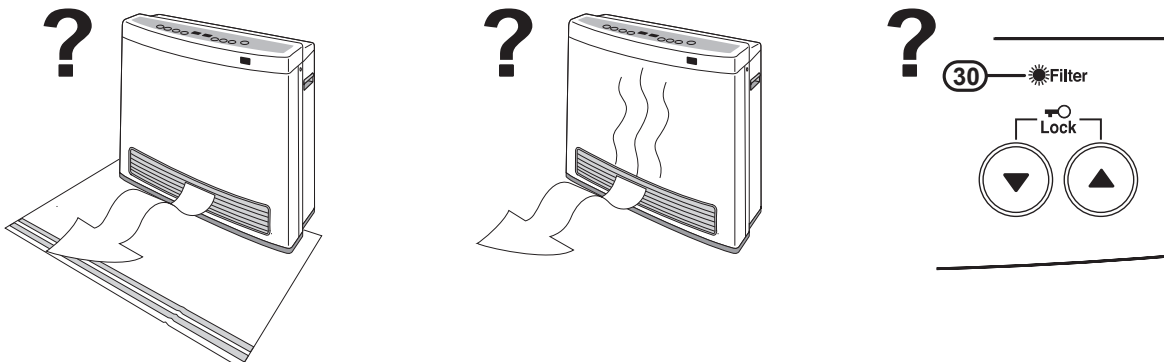

# INSTALLATION

## UNPACKING THE APPLIANCE

Check for damage. If the heater is damaged, **DO NOT INSTALL** and contact your supplier for advice.

## WHAT'S IN THE BOX

The following items should also be included in the carton: This Operation Manual and Remote Control with Battery.

## BEFORE INSTALLING THE APPLIANCE



- Check it is labelled for the correct gas type (see label on rear of heater). Refer to local gas authority for confirmation of gas type if you are in doubt
- The appliance must be installed in accordance with the local gas and electrical authority regulations.
- A dedicated 240 V Earthed 10 Amp power point must be used with this appliance.
- For information on gas consumption, see data plate on the appliance.
- When using this appliance, ensure that the room is correctly ventilated, in accordance with the section “VENTILATION” on page 8 and the warning label located on the appliance. For further information regarding room ventilation contact Rinnai or your local gas authority.
- **DO NOT USE THIS APPLIANCE TO HEAT A BEDROOM, BATHROOM, TOILET, COMBINED LIVING/SLEEPING AREA OR SAUNA.**
- **DO NOT CONNECT TO A PROPANE (LPG) GAS CYLINDER INDOORS.**
- This appliance must not be installed where curtains or other combustible materials could come into contact with it. In some cases curtains may need restraining.
- This appliance is not designed to be built in.
- This appliance must not be located below a power socket-outlet.
- If you move house, check the gas type in the area where you are moving to.
- The local gas and electrical authorities will be able to advise on local regulations.
- This appliance discharges a large volume of warm air at low level to provide even heat distribution. If the air in the room contains cooking vapour or cigarette smoke, and the heater is used on a carpet, the surface of the carpet may become discoloured. In addition, some nylon carpets contain dyes which may be affected by the warm air flow. Some soft vinyl surfaces are also subject to distortion, or discolouration by warm air. To prevent discolouration of carpets etc, a mat should be placed under the appliance extending about 750 mm in front of it.
- The appliance is not intended for use by young children or infirm persons without supervision.
- Young children should be supervised to ensure they do not play with the appliance.
- If the supply cord or gas hose are damaged or require replacing, they must be replaced by the manufacturer or the manufacturer's agent or similarly qualified person in order to avoid a hazard.
- The Avenger / Blaze heaters weigh 12 kg and the Dynamo / Enduro heaters weigh 10 kg. Exercise caution when lifting or moving an appliance.

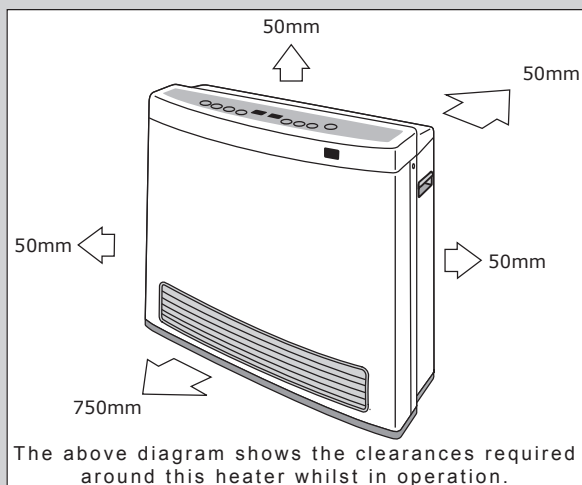

# INSTALLATION

## CHECKING ROOM SIZE

The heaters **MUST NOT** be installed in a room smaller than specified, these are:

The Avenger 25 minimum room size 62.5 m<sup>3</sup>.

The Blaze 21 minimum room size 52.5 m<sup>3</sup>.

The Dynamo 15 minimum room size 37.5 m<sup>3</sup>.

The Enduro 13 minimum room size 32.5 m<sup>3</sup>.

To determine if the intended room meets the minimum size requirements simply multiply the Height x Width x Depth. For example if the room dimensions are Length 5.3 metres, Width 5.0 metres and Height 2.4 metres then the volume would be 63.6 m<sup>3</sup> and suitable for use with an Avenger 25.

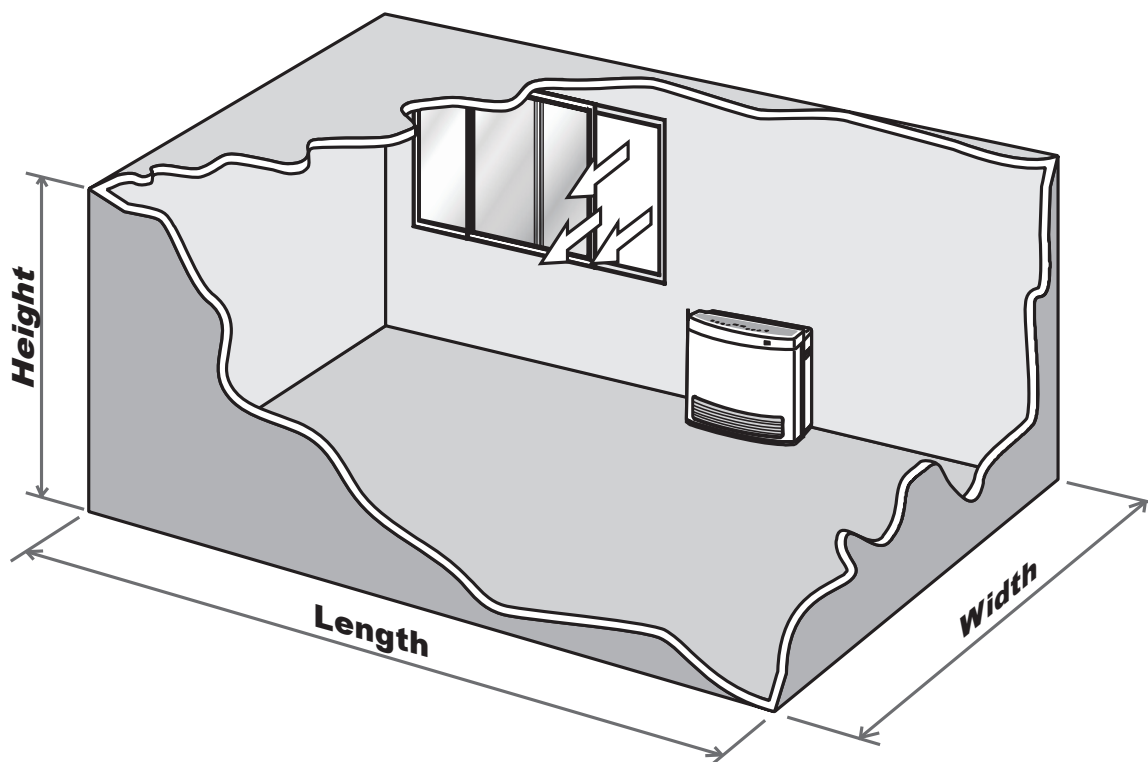

**DO NOT** use this appliance to heat a bedroom, bathroom, toilet, combined living/sleeping area or sauna.



If you require more information regarding your local ventilation requirements contact Rinnai (see back page for contact details) or your local gas regulatory authority.

## GAS CONNECTION

The bayonet plug on the factory fitted flexible hose simply plugs into your bayonet fitting.

# HOW TO OPERATE THE HEATER

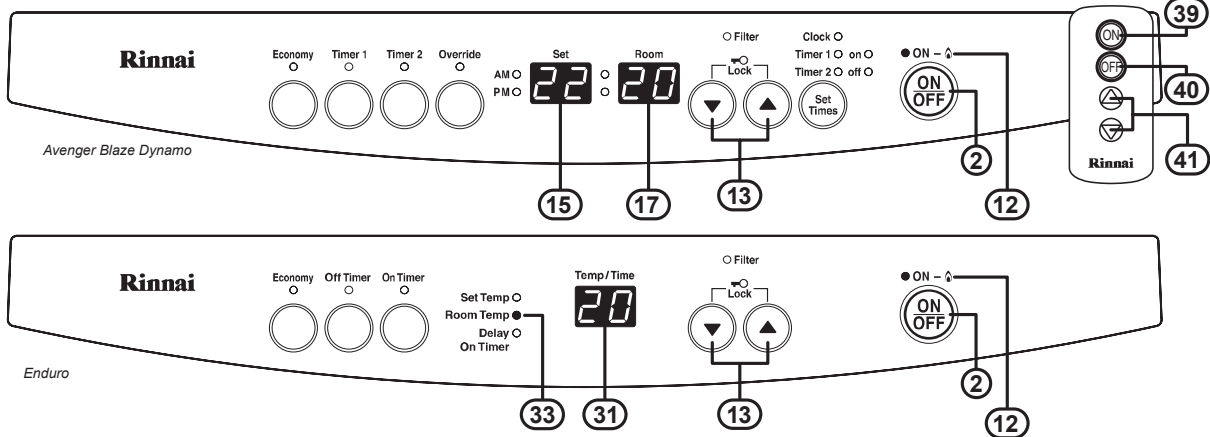

## TO TURN THE HEATER ON

Before you begin, ensure that the Gas and Power have been connected correctly to the appliance.

To turn the appliance on press the ON/OFF button (2) located on the control panel. For models that are equipped with a remote control the ON button (39) may also be used.

When pressed the appliance will begin to operate in the following factory preset manner:

- The default set temperature will be 22° C (15).
- The current room temperature will be displayed (17), (31) / (33)
- The On/Combustion indicator (12) will illuminate Green (steady). Ignition will take 5 ~ 10 seconds. The ON/Combustion indicator will change to Red (steady) after proper ignition has been achieved to signify the correct burner operation.



**When using the appliance for the first time or after long periods of disuse, ignition may not occur the first time it is operated as there may be air within the pipes. If ignition does not occur after approximately 30-seconds the unit will cease operation automatically. If this occurs press the ON/OFF button (2) twice to restart. For models that are equipped with a remote control the press the OFF button (40) and then press the ON button (39) to restart.**

**The unit may make noises after ignition/extinction. This is due to expansion and contraction of the heater components and is normal.**

**The heater will not immediately ignite if the ON/OFF button (2) is pressed straight after extinction. After approximately 20 seconds has passed, the heater will automatically go into ignition mode.**

## TO ADJUST SET TEMPERATURE

The set temperature may be raised or lowered by use of the Up and Down buttons (13) located on the control panel. For models that are equipped with a remote control the Up and Down buttons (41) may also be used.

The following "SET" temperatures can be selected.

- 'L' for continuous combustion on lowest burner setting, without thermostatic control.
- Thermostatic control between 16° C to 26° C in 1° C steps
- 'H' for continuous combustion on highest burner setting, without thermostatic control.

The room temperature will display temperatures between 1° C to 30° C.

Once the temperature is set it will be stored in the microcomputers memory, if the temperature is not adjusted further it will be available as the initial setting when the appliance is next used.



**Rooms may not arrive at the "SET" temperature due to the size and construction of the room, location of the appliance or external temperatures.**

**If the appliance does not ignite then the actual room temperature may be higher than the pre-set temperature selected.**

# HOW TO OPERATE THE HEATER

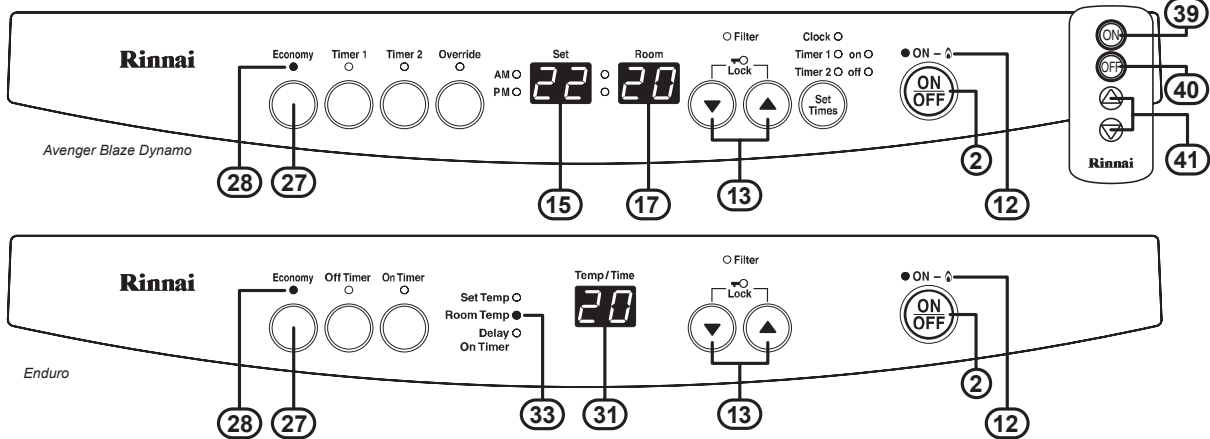

## TO TURN THE HEATER OFF

To turn the heater off while it is in operation press the ON/OFF button (2) located on the control panel. For models that are equipped with a remote control the OFF button (40) may also be used.

The On/Combustion indicator (12) will go out.



**After the On/Combustion indicator (12) has gone out, the appliance fan will continue to cycle for several minutes. This is to lower the temperature within the appliance and is normal. DO NOT disconnect the power during this time.**

## USING THE ECONOMY MODE

As a room is warmed, the walls and ceilings are also warmed, making one feel a little warmer than when the ceilings and walls were cold, even though the room temperature is the same. The Economy mode prevents discomfort from overheating and saves energy.

When the Economy mode is selected the appliance will heat the room. Once the set temperature has been maintained for a period of 30 minutes, the comfort control system will progressively lower the set temperature by 2°C over a period of 60 minutes.

To operate the heater in Economy mode, press the Economy button (27) while the appliance is in operation. The Economy indicator (28) will illuminate to show the appliance is now operating in Economy mode.

To cancel Economy mode press the Economy button (27) and the Economy indicator (28) will go out to show that the economy mode has now been cancelled.

# TIMER OPERATION - AVENGER, BLAZE & DYNAMO

## CLOCK AND DUAL TIMERS

The setting of the Clock and programming of the Timers is done via the Set Times button (18). Each press of this button will cycle the appliance through the available clock setting and timer programming modes that are available.

### CHECKING THE CLOCK

One press of the Set Times button (18) displays the current time that the clock is set to.

### SETTING THE CLOCK

One presses of the Set Times button (18) selects the clock setting mode, allowing the current time to be adjusted. When in this mode the 'Clock' indicator (19) is illuminated

The factory default clock time is PM 12:00.

Press the Up or Down buttons (13) to adjust the clock to the desired time.

Pressing and holding either the Up or Down buttons (13) will scroll digits, at first by minute (17) intervals and then by hour (15) intervals. When adjusting the time ensure that the correct AM or PM (14) setting is observed.

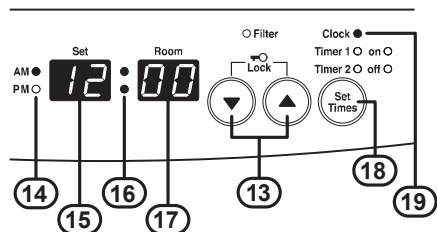
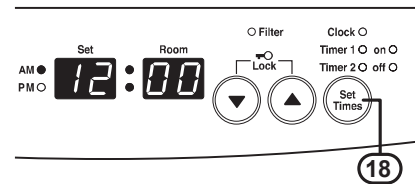

**To lock in the new clock time and exit the Clock and Timer setting mode without altering the Timer 1 or Timer 2 settings press the Set Times button (18) five times.**

## PROGRAMMING TIMER 1

Two presses of the Set Times button (18) selects the Timer 1 'On' programming mode which allows adjustment of the time when the heater switches 'On' (or starts). The Timer 1 and On indicators (20) are illuminated.

The factory default Timer 1 'On' time is AM 06:00. Press the Up or Down buttons (13) to adjust the Timer 1 'On' time.

Pressing and holding either the Up or Down buttons (13) will scroll digits, at first by minute (17) intervals and then by hours (15) intervals. When adjusting the time ensure that the correct AM or PM (14) setting is observed.

Pressing the Set Times button (18) again (three presses from the beginning) selects the Timer 1 'Off' programming mode which allows adjustment of the time when the heater switches 'Off' (or stops). The Timer 1 and Off indicators (20) are illuminated.

The factory default Timer 1 'Off' time is AM 09:00. Press the Up or Down buttons (13) to adjust the Timer 1 'Off' time.

Pressing and holding either the Up or Down buttons (13) will scroll digits, at first by minute (17) intervals and then by hours (15) intervals. When adjusting the time ensure that the correct AM or PM (14) setting is observed.

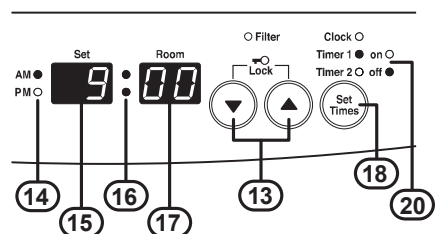
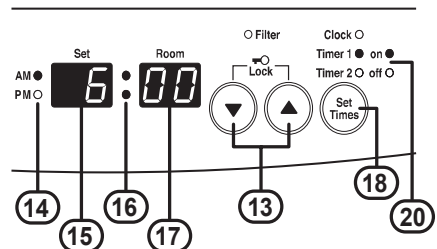

**To lock in the new Timer 1 on and off timer programs and to exit the Clock setting and Timer programming mode without altering the Timer 2 settings press the Set Times button (18) three times, otherwise continue to "PROGRAMMING TIMER 2" on page 12.**

# TIMER OPERATION - AVENGER, BLAZE & DYNAMO

## PROGRAMMING TIMER 2

Pressing the Set Times button (18) again after setting programming Timer 1 (four presses from the beginning) selects the Timer 2 'On' programming mode which allows adjustment of the time when the heater switches 'On' (or starts). The Timer 2 and On indicator (20) are illuminated.

The factory default Timer 2 'On' time is AM 06:00. Press the Up or Down buttons (13) to adjust the Timer 2 'On' time.

Pressing and holding either the Up or Down buttons (13) will scroll digits, at first by minute (17) intervals and then by hour (15) intervals. When adjusting the time ensure that the correct AM or PM (14) setting is observed.

Pressing the Set Times button (18) again (five presses from the beginning) selects the Timer 2 'Off' programming mode which allows adjustment of the time when the heater switches 'Off' (or stops). The Timer 2 and Off indicator (20) are illuminated.

The factory default Timer 2 'Off' time is AM 09:00. Press the Up or Down buttons (13) to adjust the Timer 2 'Off' time.

Pressing and holding either the Up or Down buttons (13) will scroll digits, at first by minute (17) intervals and then by hour (15) intervals. When adjusting the time ensure that the correct AM or PM (14) setting is observed.

Pressing the Set Times button (18) again (or six presses from the beginning) will exit programming mode and return the appliance to normal operation.

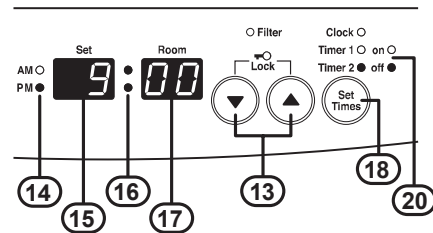
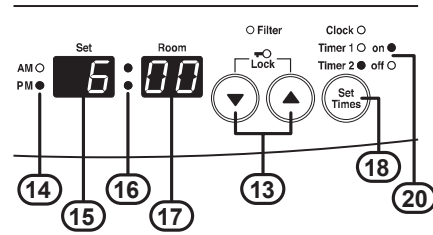

## OPERATING TIMERS

Turn the appliance on by pressing the ON/OFF button (2) located on the control panel or the ON button (39) of the remote control.

Set the desired temperature and select the economy mode if required.

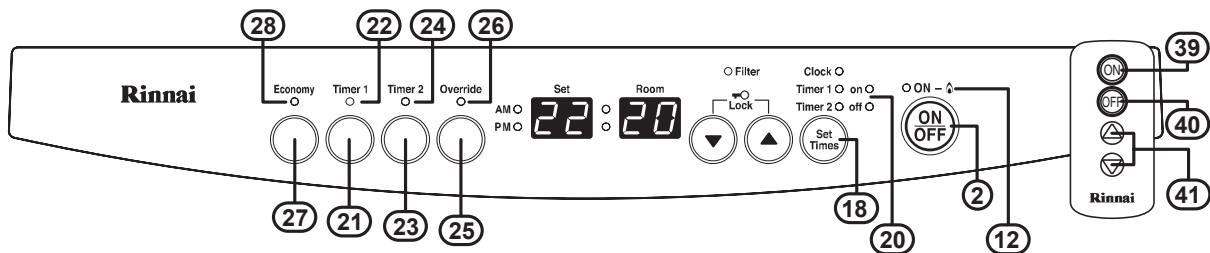

**Timer 1 and Timer 2 may be operated together or individually.**

**The heater will continue to operate under control of the timers until timer operation is cancelled.**

To select operation by Timer 1 press the Timer 1 (21) button. The Timer 1 indicator (22) will illuminate steady to show that the heater is waiting for the programmed 'on' time to be reached.

To select operation by Timer 2 press the Timer 2 (23) button. The Timer 2 indicator (24) will illuminate steady to show that the heater is waiting for the programmed 'on' time to be reached.

The heater automatically turns itself on once the 'on' time of the selected timer(s) is reached and the associated Timer indicator (22) or (24) will flash while the heater is operating under timer control.

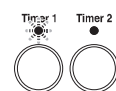

When the 'off' time of the selected timer is reached the heater will automatically turn off and the Timer indicator will illuminate steady to indicate the heater is waiting for the next programmed timer cycle to begin.

To cancel timer(s) operation press the associated timer button(s). The indicator will go out to signify that the heater is now operating under manual control.

# TIMER OPERATION - AVENGER, BLAZE & DYNAMO

## PREHEAT

This function operates automatically in conjunction with the Timers. When a Timer is selected, the heater may operate anywhere within an hour prior to the programmed starting time of a Timer.

This function is called Pre-heat since it ensures the room reaches the desired temperature by the On Time programmed into the Timer(s). The room temperature is sensed one hour before the programmed On Time.

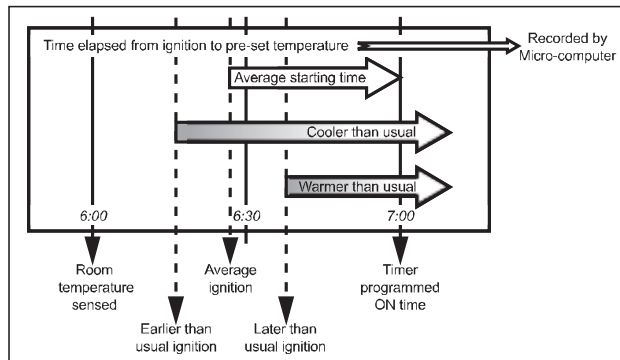

The temperature differential at the time of sensing the room temperature combined with the data from previous operation governs exactly how long before the programmed On time the micro-computer will operate the heater and ignite the burner.

## USING THE OVERRIDE FUNCTION

This function is used to manually override the current operation of the heater. For example: if the heater is between the finishing and starting times of a timer program and the Override button is selected, then the heater will begin to operate and heat the room.

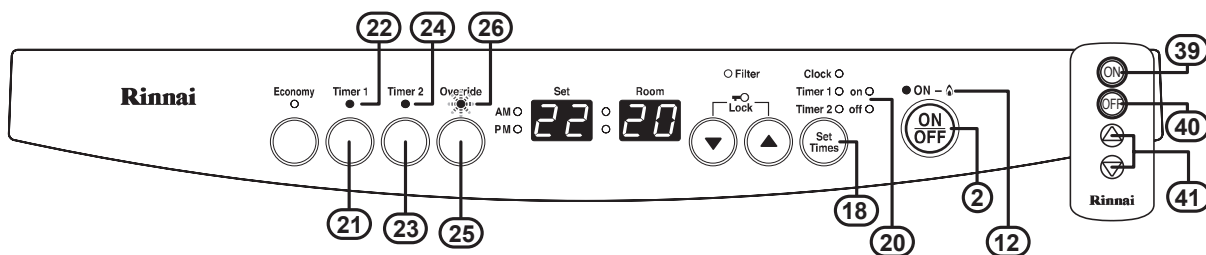

The heater must be between the finishing and starting times of a timer program for the Override to function to work. Either of the Timer indicators (22) or (24) will be illuminated and the Combustion indicator (12) is illuminated green when this is the case. If the Override button (25) is pressed the Override indicator (26) will flash to show that the heater is now operating in override mode. The heater will now start and full manual control will now be available.

To cancel override and to return to Timer operation press the Override button (25) again. The Override indicator (26) will go out and the Combustion indicator (12) will be illuminated green to confirm that timer operation has been restored and that the heater is awaiting a timer operation to begin. If the Override button (25) is not pressed the heater will remain on until the next programmed Off time setting is reached.



**If the ON/OFF button (2) or the OFF button (40) on the remote control are pressed the heater will be turned off and the timer programs will not operate.**



# TIMER OPERATION - ENDURO

## OPERATING THE ON TIMER

The Delay On Timer allows you to delay the start time of the heater for up to 24 hours.

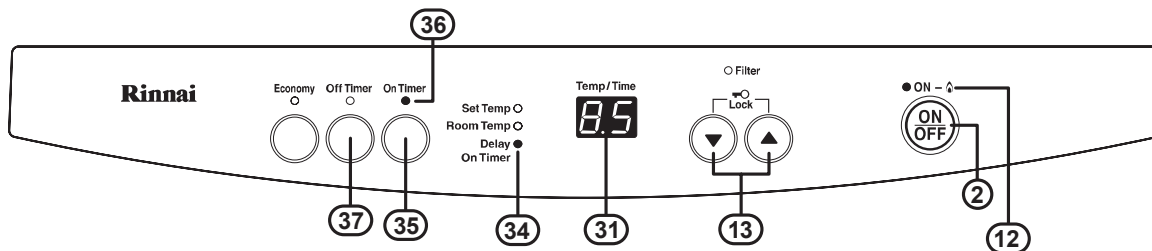

To operate, press the On Timer button (35). The On Timer indicator (36) will illuminate and the Combustion indicator (12) will be illuminated green to confirm that the heater is awaiting for the Delay 'on' time period to pass before commencing operation. The Delay On timer indicator (34) will also illuminate and the current Delay On Time period will be displayed on the Digital (Temp / Time) display (31) for 60 seconds. Whilst displayed, the Delay On time can be adjusted by pressing the Up or Down buttons (13). A delay time of up to 9½ hours can be set in increments of 30 minutes and a delay time of up to 24 hours in increments of 60 minutes.

When the programmed Delay 'On' time period has passed, the heater will automatically begin operation.



The heater will continue to operate for a period of 60 minutes. On Timer operation can be cancelled by pressing either the ON/OFF button (2) or the Off Timer button (37).

The delay 'On' time last programmed is stored in the memory and will be the default until it is re-adjusted.

If the On Timer button (35) is pressed whilst the heater is in operation the On Timer will override manual operation.

## OPERATING THE OFF TIMER

The Off Timer allows you to set a 60 minute delay before the heater will automatically turn off.

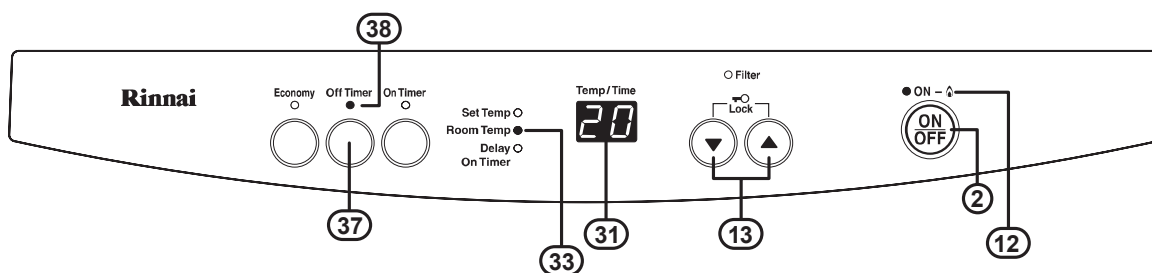

To operate, press the Off Timer button (37). The Off Timer indicator (38) will illuminate and the Combustion indicator (12) will be illuminated red to confirm that the heater will continue operation until the Delay 'off' time period has passed after which it will stop. The Delay Off time is 60 minutes. When this time has passed, the heater will automatically stop operation and the Off Timer indicator (38) will flash.

During Off Timer operation full manual control of the heater is available.



After the Off timer operation is completed press the ON/OFF button (2) twice to restart the heater.

The Off Timer and On Timers work independently of each other. However, if both timers are operating and the Delay On time period is 30 minutes, the Delay Off Timer will override the Delay On Timer.

# LOCK AND SAFETY DEVICES

## USING THE LOCK FUNCTION

The Lock function will avoid accidental operation and prevent small children from altering the heater settings.

### To Activate the Lock

To activate the Lock function press both the Up and Down buttons (13) simultaneously. The function is activated immediately and the Lock indicator (29) will be illuminated.

### To Deactivate the Lock

To deactivate the Lock function press both the Up and Down buttons (13) simultaneously for 3 seconds. The Lock indicator (29) will go out to show that the Lock function is no longer active. The Lock function can be deactivated at any time in this manner.

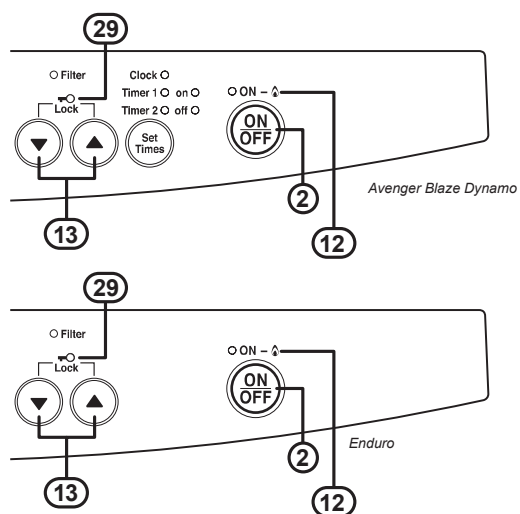

If the Lock function is activated whilst the heater is in operation or in Timer mode, all controls other than the ability to switch the appliance OFF with the ON/Off button (2) or for models with a remote control the OFF button (40) will be locked until the Lock is deactivated. Timer operation will not be affected.

If the lock function is activated whilst the appliance is in the off position, all controls will be locked until the Lock function is deactivated.

If the appliance is switched off whilst the Lock function is activated, all controls will be locked until the Lock function is deactivated.

Lock programming (activated or deactivated) is stored in the appliance memory. Unplugging the appliance from the power supply has no effect on Lock programming.

## SAFETY DEVICES

### Over heat switch

When the heater gets too hot during operation (for example when the filters or air outlet louvres are blocked) this device turns the gas off automatically.

### Electrical fuse

The electrical circuits are protected by a fuse.

### Flame failure sensor

This device automatically cuts off the gas supply to the heater in the event of a gas failure.

### Oxygen depletion sensor

If the oxygen level in the room drops below a pre-set limit, this device cuts the gas supply to the heater.

### Tilt switch

If the heater is knocked over, the tilt switch will cut the gas supply. The fan keeps cycling.

### Power failure

In the event of a power failure or power cut, the gas valves will automatically close.

# CARE AND MAINTENANCE

Your heater needs very little maintenance, but the following information will help you to keep it looking good and working efficiently.



**Unplug before cleaning.**

**All parts of the heater can be cleaned using a soft, damp cloth.**

**DO NOT use solvents to clean any parts.**

**DO NOT spray aerosols in the vicinity of the heater whilst in operation.**

**DO NOT place articles on or against this heater.**

**DO NOT store flammable materials near this heater.**

## AIR FILTERS

Dusty filters reduce heating effectiveness.

**DO NOT** wait for Filter indicator (30) to come on before cleaning filters.

**DO NOT** use the heater with the filter warning lamp on. This may cause it to overheat.

## REMOVING FILTERS

Filters require cleaning at least once a week during the heating season to prevent blockages.

For cleaning Filter 1 (7), undo and remove the retaining screw (ensure the retaining screw is stored in a safe place).

Carefully lift filters up then backwards to remove from locating tabs.

With the careful use of a vacuum cleaner, gently remove any contaminants such as dust and lint being careful not to damage the filter mesh.

Replace filters by carefully repositioning the location tabs and fasten in place with the retaining screw.

Filter 2 (8) (the small filter) should be left in position for cleaning, carefully use a vacuum cleaner to remove any contaminants such as dust and lint.

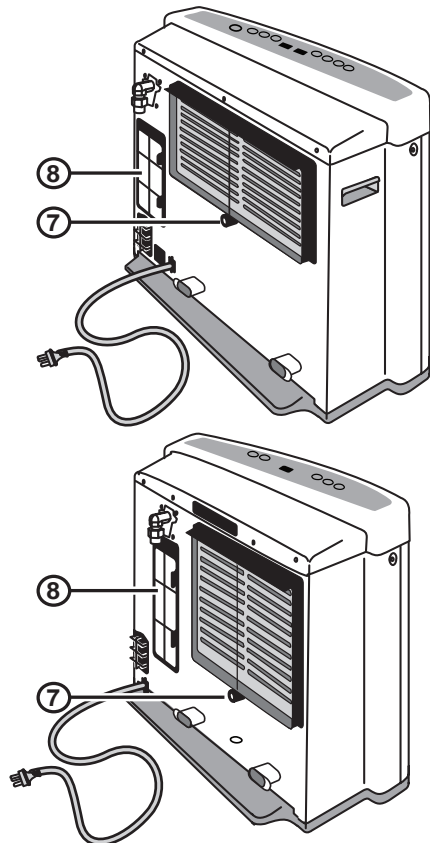

**Do not operate this appliance without filters (7) and (8) in place or if the mesh is damaged**

## SERVICE

Rinnai recommend that this appliance and installation be inspected and serviced every 2 years.

If the power supply cord or any other component of the heater are damaged, they must be replaced by Rinnai or a suitably qualified person.

Any service or repair work should only be carried out by an authorised person. For the location of your nearest service centre call 0800 2 Rinnai.



**Service calls for general cleaning, maintenance and wear and tear are not necessarily covered under the warranty. Service calls of this nature may be chargeable.**

# CARE AND MAINTENANCE

## TROUBLE SHOOTING CHECKLIST

Use the following chart to help determine whether a service call is required, however if you are unsure about the way your heater is operating, contact Rinnai or your local agent.

Fault Condition	→	No Display	Burners fail to ignite	Filter Indicator is illuminated	Combustion stops during operation	Smell of gas	Takes a long time to warm the room	Remote control doesn't work	Possible Remedy
Not plugged in or turned off.		●	●				●		Plug in power cord and turn power on.
Mains power failure.		●	●		●			●	Re-ignition, when power restored, page 9.
(Initial Install) Air in gas pipe.			●						Installer to purge air from gas supply.
Air in hose			●						Repeat Ignition procedure page 9.
Room too large							●		Check with retailer.
Dust on air filters				●					Clean the air filters (Weekly).
Louvre obstructed					●		●		Remove obstruction
Air filter blocked					●		●		Clean the air filters (Weekly).
Gas escape						●			Isolate gas supply, call Rinnai service.
Gas supply turned off.		●	●						Turn gas supply on at the meter or cylinder.
Lock set.			●						Cancel Lock as described on page 15.
On Timer is set.			●						Cancel timer by using the override page 13.
Flat batteries.								●	Replace remote control battery.

## ERROR CODES

Your heater is also fitted with self diagnostic electronics that monitor the appliance during start-up and operation. Should a fault occur the heater will shut down and the cause fault will be indicated by a pair of flashing digits in the Digital display (17) or (31) depending on the model and the On/Combustion indicator (12) will also flash Red. Refer to the table below for probable cause and the suggested remedy

Code	Probable Cause	Suggested Remedy
00	Mains power failure during operation	Press the ON/OFF button ② twice to reset heater.
03	Tilt switch activated	Ensure appliance is level & upright. Service call if repeated.
11	Ignition failure	Check gas supply is turned on, turn the heater OFF and then ON again. If the heater fails to ignite after 4 attempts a Service call will be required.
12	Incomplete combustion	As above.
13	Combustion control faulty	Service call.
14	Filter Blockage / Overheat	Clean filters. If error continues a service call will be required.
16	Room overheat	Lower room temp to below 40°C.
18	Temperature sensor faulty	Service call.
31	Room temperature sensor faulty	Service call.
32	Overheat temperature sensor faulty	Service call.
33	Overheat temperature sensor faulty	Service call.
34	Overheat temperature sensor faulty	Service call.
62	Faulty fan motor	Service call.
70	ON/OFF switch faulty	Service call.
71	Solenoids faulty	Service call.
72	Flame detection circuit fault	Service call.
73	Communication error	Press the ON/OFF button ② twice to reset heater. Service call if repeated.

# SPECIFICATIONS

## GENERAL SPECIFICATIONS

General Description:	Portable Gas Convector Heaters.	
Gas Control:	Electronic control	
Burner	Surface Combustion Burner	
Gas Connection:	3/8" MI BSP into 1.5 metre flexible gas hose with bayonet connection	
Convection Fan:	Multi Speed Fan	
Ignition System:	Continuous spark electronic ignition	
Operation:	Push button electronic, remote control (Avenger, Blaze, Dynamo)	
Safety Devices:	Over Heat Switch Electric Fuse Flame Failure Sensor	Oxygen Depletion Sensor Tilt Switch Power Failure

## WEIGHT AND MEASURES

Model	Gas Input (MJ/hr)			Supply Pressure (kPa)		Dimensions (mm)	Weight (Kg)
	Burner Rate	Natural Gas	LP Gas	Natural Gas	LP Gas		
Avenger 25 (RCE 671 TR)	Low	8.5	8.5	1.13	2.75	A = 610 B = 482 C = 239 D = 202	12
	High	25.0	24.0				
Blaze 21 (RCE 571 TR)	Low	8.5	8.5				
	High	21.0	21.0				
Dynamo 15 (RCE 471 TR)	Low	6.0	6.0				
	High	15.0	15.0				
Enduro 13 (RCE 371)	Low	6.0	6.0	10			
	High	13.0	13.0				

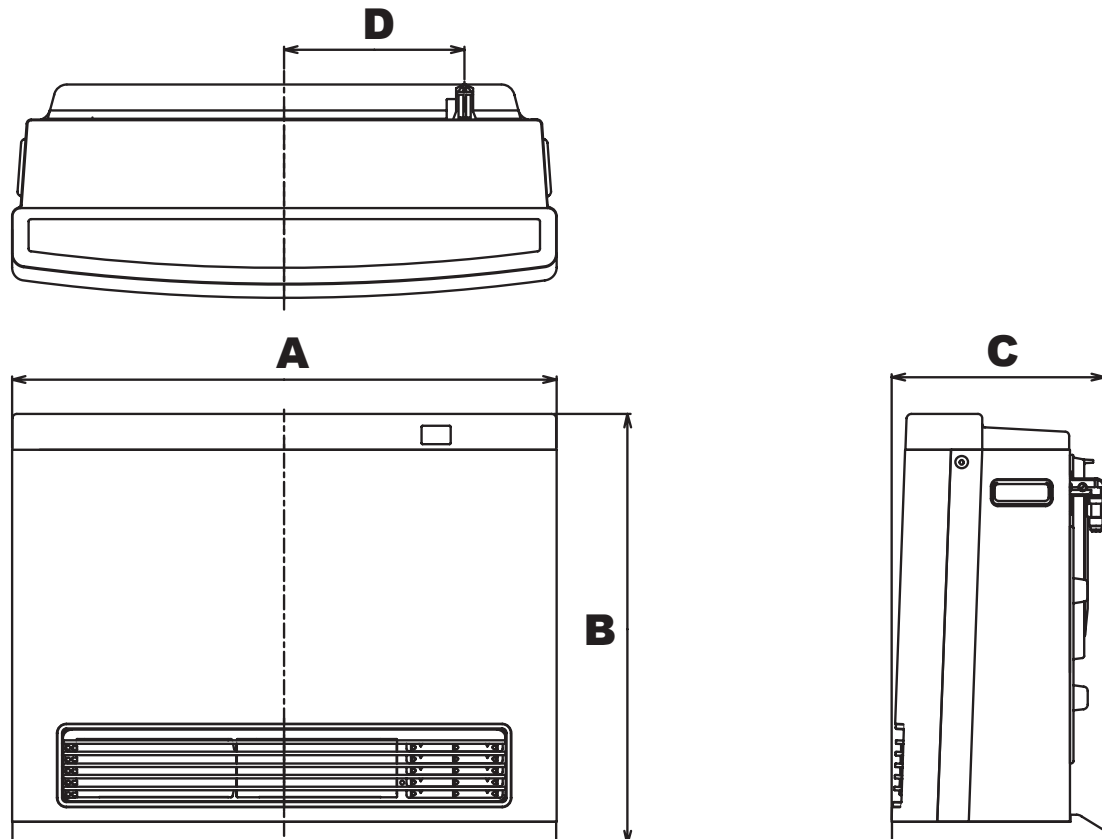





# Rinnai

**Rinnai**  
NEW ZEALAND LTD.

**Rinnai New Zealand Limited**

105 Pavilion Drive  
Airport Oaks  
Mangere  
Manukau

PO Box 53177  
Auckland Airport  
Manukau 2150

Phone: (09) 257 3800  
Fax: (09) 257 3899

Rinnai has a Service and Spare Parts network with personnel who are fully trained and equipped to give the best service on your Rinnai appliance. If your appliance requires a service, please call 0800 RINNAI. Rinnai recommends that this appliance be serviced every 2 years.

Website: [www.rinnai.co.nz](http://www.rinnai.co.nz) E mail: [info@rinnai.co.nz](mailto:info@rinnai.co.nz)

**Consumer Enquiries**

Phone: 0800 RINNAI (0800 746 624)

**Installer Enquiries**

Phone: 0800 TO RINNAI (0800 86 746 624)



109739

RC-671-42X04(00)

Printed in Japan 2012.06