

**Rinnai**

Operation guide

---

Arriva 752



## Important:

Appliance must be installed with a Rinnai approved flue system.

This appliance shall be installed in accordance with:

- Manufacturer's installation instructions
- AS/NZS 5601
- Local regulations and municipal building codes

Installation, servicing and repair shall be carried out only by authorised personnel.

Please retain this manual for future reference.

### **Warning**

Improper installation, adjustment, alteration, service or maintenance can cause property damage, personal injury or loss of life.

---

For more information about buying, living and servicing of Rinnai appliances call: 0800 RINNAI (0800 746 624)

Rinnai New Zealand Limited  
105 Pavilion Drive, Mangere, Auckland  
PO Box 53177, Auckland Airport, Auckland 2150

Phone:(09) 257 3800, Fax: (09) 257 3899  
Email: [info@rinnai.co.nz](mailto:info@rinnai.co.nz), [www.rinnai.co.nz](http://www.rinnai.co.nz)

# contents:

About your Arriva 752	4
Safety	5
Clearances	6
General information	7
Operation without the remote	8
Operation using the remote	9
Care of your Arriva 752	11
Maintenance and servicing	12
Troubleshooting	14
Error codes	16
Abnormal flame pattern	17
Installation checklist	18
Installer details	18
Limited warranty	19

# About your Arriva 752

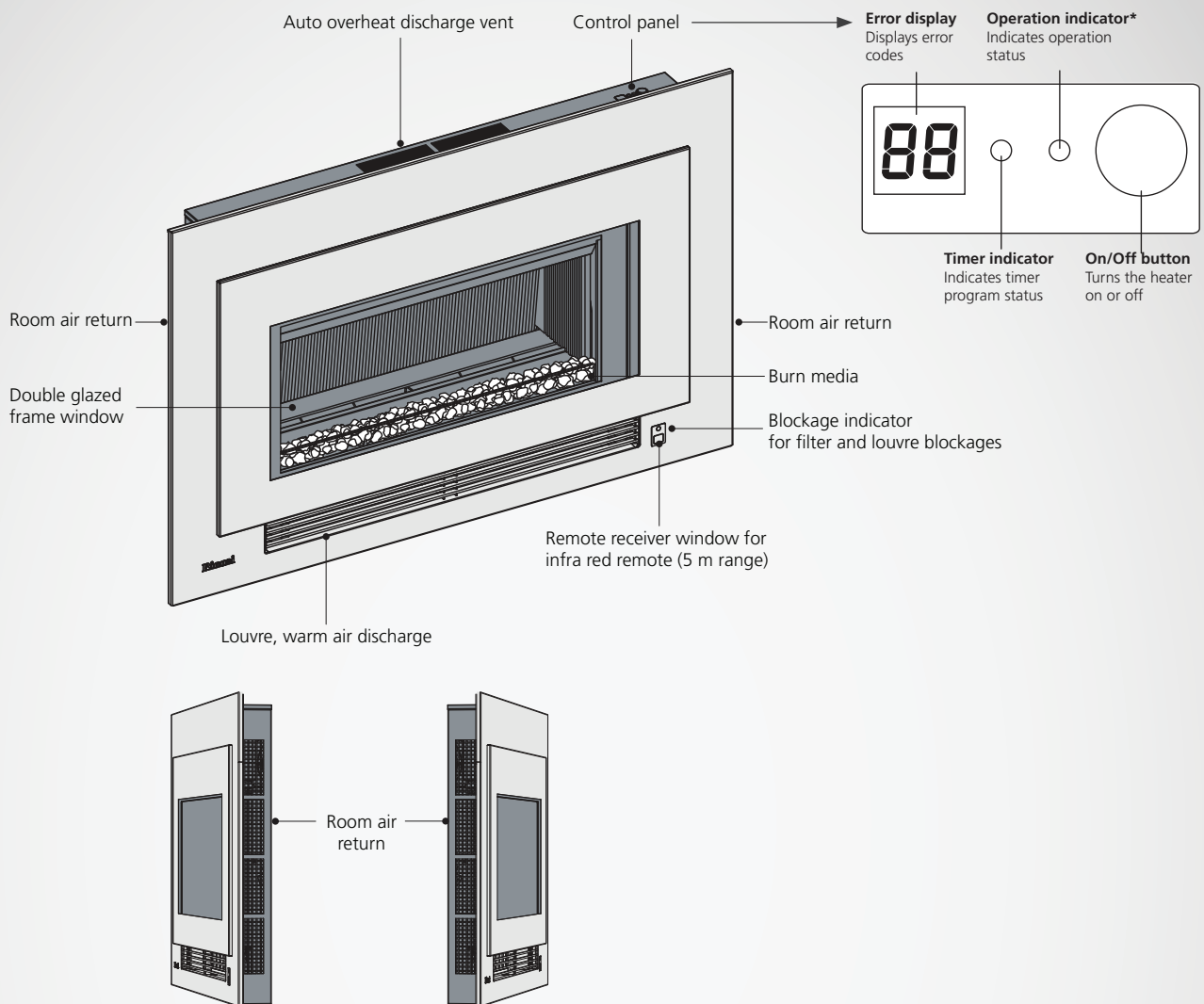

Beauty and efficiency rolled into one great fireplace. Elegant and stylish—with six beautiful fascia options and modern quartz or pebble burn media. High performance and resource considerate, the Arriva 752 ensures the highest heat output for the lowest energy consumption.

\* Control panel operating colours; red - on, green - standby, green flashing - error code indication

# Safety

## Important

This appliance is not intended for use by persons (including children) with reduced physical, sensory or mental capabilities, or lack of experience and knowledge, unless they have been given supervision or instruction concerning use of the appliance by a person responsible for their safety.

- THE HEATER MUST NOT BE USED IF THE GLASS OR PANELS ARE DAMAGED
- DO NOT PLACE ARTICLES ON OR AGAINST THIS APPLIANCE
- DO NOT USE OR STORE FLAMMABLE MATERIALS NEAR THIS APPLIANCE
- DO NOT MODIFY THIS APPLIANCE
- DO NOT SPRAY AEROSOLS IN THE VICINITY OF THIS APPLIANCE WHILE IT IS IN OPERATION



Do not restrict warm air discharge by placing articles in front of the appliance.

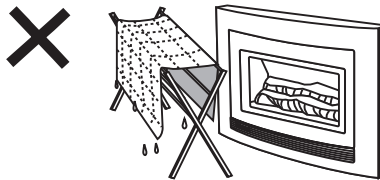

This appliance must not be used for any other purpose other than heating.

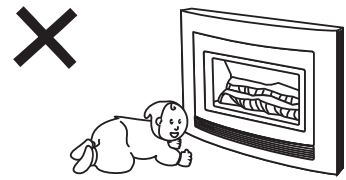

Children should be supervised at all times to ensure they do not play with the appliance. Hand or body contact with the appliance must be avoided.



Do not allow anyone to sit, lean or sleep directly in front of the appliance.

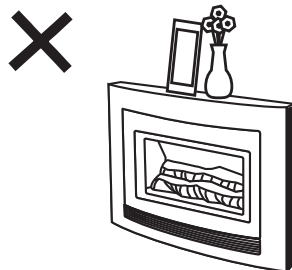

Do not place articles on the top panel or obstruct the automatic overheat discharge vent.

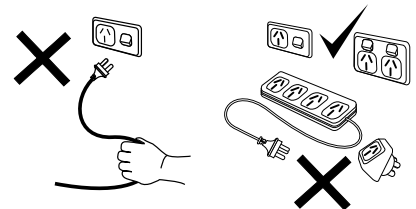

Do not unplug the appliance while it is operating. Do not use power boards or double adaptors to operate this appliance.

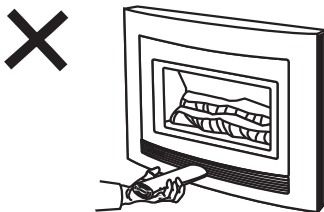

Do not allow anyone to post articles through into the heater.

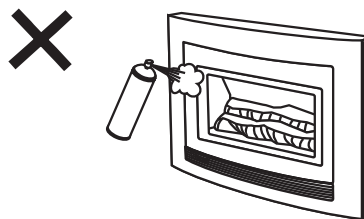

Do not spray aerosols while the appliance is operating. Most contain butane gas which can be a fire hazard if used near the appliance.

# Clearances

The clearances listed below are minimum clearances unless otherwise stated.

## Clearances around the heater

The appliance must not be installed where curtains or other combustible materials (coffee tables, couches etc.) could come into contact with the heater. In some cases curtains may need restraining.

## Floor protection

Heat emanating from this fire may over time affect the appearance of some materials used for flooring, such as, carpet, vinyl, cork or timber. This may be amplified if the air contains cooking vapours or cigarette smoke. To avoid this occurring, it is recommended that a mat be placed in front of the appliance.

## Mantels and surrounds

Mantels and surrounds are allowed providing they conform to the minimum clearances shown. These clearances are important as they:

- allow heat to escape in the event of a power failure during operation
- allow optimum performance of the heater (room air return)
- allow access to the side mesh filters

### Clearance calculation example

At a 75 mm vertical clearance, the maximum mantel depth is 25 mm. For every 25 mm of added mantel depth, there must be an additional 25 mm of vertical clearance. For example a mantel depth of 100 mm requires a vertical clearance of 150 mm

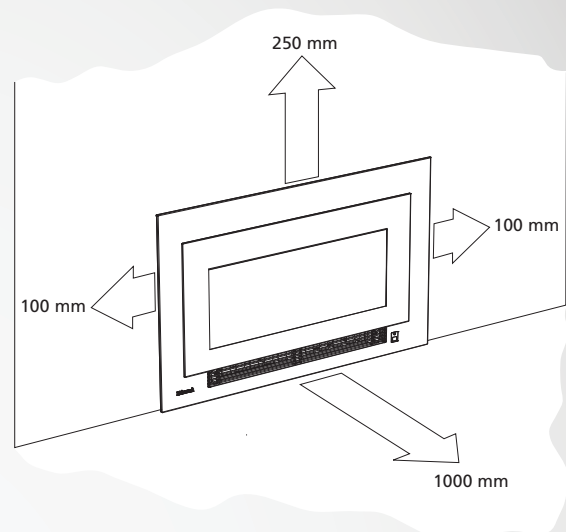

Clearances required around the heater when operating

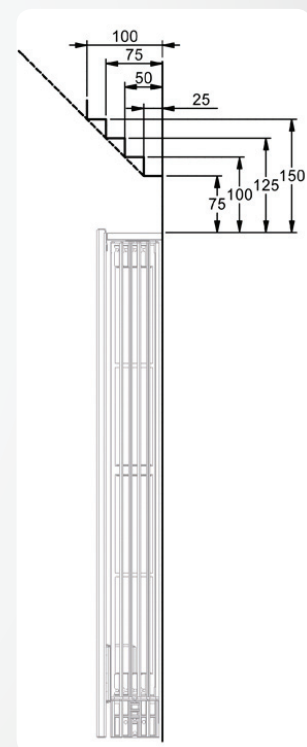

Arriva 752 mantel clearances



Arriva 752 surround clearances

# General information

Before operation please read these instructions to get an overview of how to operate, maintain and service your Rinnai gas fire.

## Electrical connection

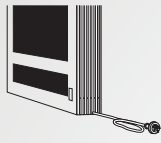

The Arriva 752 is fitted with a 1.5 m power cord and 3-pin plug. The standard electrical

connection is to the right hand side of the heater front assembly. If necessary this can be changed by your electrician to terminate on the left.

The connection is either direct wired or connected to a power point within the cavity. This must be connected to a dedicated earthed power point. The electric isolation switch must be accessible after the appliance has been installed. The heater must not be located immediately below a socket outlet (potential fire hazard).

If the supply cord is damaged, it must be replaced by a licensed tradesperson. This must be a genuine replacement part available from Rinnai, part number 6765B.

## Hearths

A hearth is not necessary, but can be used for decorative purposes or protection of sensitive flooring if required. General guidelines if installing a hearth.

- It must not obscure the front of the fire
- The bottom of the appliance must be level with the top of the hearth so there is a continuous level
- Size should be at least the width and depth of the fire

## Installation by a licensed tradesperson

Ensure your installer talks to you about the use and care of this appliance, and that you understand these instructions. The installer also needs to complete the appliance installation checklist and installer details, and leave this guide with you.

## Positioning the Arriva 752

To gain maximum heating advantage from the bottom air discharge, position the Arriva 752 close to the floor.

The unit can be fully recessed as long as the mantel and surround clearances on the previous page are maintained.

## Power failure

If the power is disrupted while the heater is operating, once the power is restored, the heater will go into power failure mode—on the control panel there will be flashing zeros in the error display, and the LED will flash green.

To reset the heater, press the On/Off button on the control panel twice, or use the remote control and press the Standby/On button once (to go on standby) and then a second time to turn the heater on.

## Safety devices

Your Rinnai Arriva 752 is designed with the following safety devices:

- flame failure sensing system
- pressure relief
- overheat safety switch
- air temperature sensor
- thermal fuse
- overcurrent fuse
- spark detector

## Soot deposits

Small soot deposits inside the heater or glass is normal. Significant build up however is not normal and will require a service call. Refer to the troubleshooting section for further information.

## TV installation above the fireplace



If installing a flat screen television above the fire, the main issue is heat, heat from the appliance, and heat from the flueing components that may sit behind the television (especially if recessed).

The Arriva 752 has a fan that distributes warm air at a low level. This pushes heat out and around the room as opposed to straight up, so installation of a television may be an option. The Arriva 752 also has a power flue that has virtually zero clearance to any cavity in which it is installed. The flueing components are also small and generate very little heat.

Generally the bottom of the television recess should be at least 450 mm above the fire. Please check with the television supplier to check clearances. Some television manufacturers have warranty conditions that state a television is not to be installed above a fireplace.

# Operation without the remote

## Ignition

This appliance has a sealed combustion chamber that requires purging before gas can flow and the unit can start. This means the combustion fan will start several seconds before the unit comes on.

Normal ignition sequence:

1. When the On/Off button is pressed on the control panel, the LED will glow red and the combustion fan will start.
2. The ignition sparker will operate and as soon as a spark is sensed gas will flow to the main burner.
3. When the main burner has established, the heater will automatically modulate between the burner settings to achieve and maintain the default set temperature of 22 °C.

If the heater is turned off using the On/Off button on the heater control panel, when it is turned back on, it will lose any timer and clock settings until the remote is used to re-transmit the information. The remote stores the clock, timer, and temperature settings of the heater.

## Do not unplug power supply

Do not unplug the main power supply to turn the unit off as the convection fan is required to operate for several minutes after the unit is turned off to assist in cooling the unit down.



# Operation using the remote

For the remote control functions to be available, the appliance On/Off button must be in the on position.

## General information about the remote control

The remote control emits an infra-red signal. It must be aimed at the receiver unit located on the right side of the unit, normal operating range is 5 m. Some fluorescent lights may interfere with the transmission of the remote signal. If you experience this problem, changing position from which you are operating the remote may help.

Unless the remote display is deactivated or the lock function is activated, the remote control will transmit information to the heater every time a button is pressed.

When the timers are being set, information is transmitted only when the 'Time Set' button is pressed.

When the remote is not used for a period of approximately five seconds, the display will default to standby mode, displaying only the time. To reactivate press any button on the keypad.

## Signal transmissions



Signal transmissions are confirmed by a brief illumination of the signal indicator on the remote.

The unit will also flash and beep to confirm the settings have been received.

## Batteries



The remote uses two x 1.5 V AAA batteries. Never mix old and new batteries.

Remove the batteries if the remote is not going to be used for a long time. This will help avoid damage from leaking batteries.

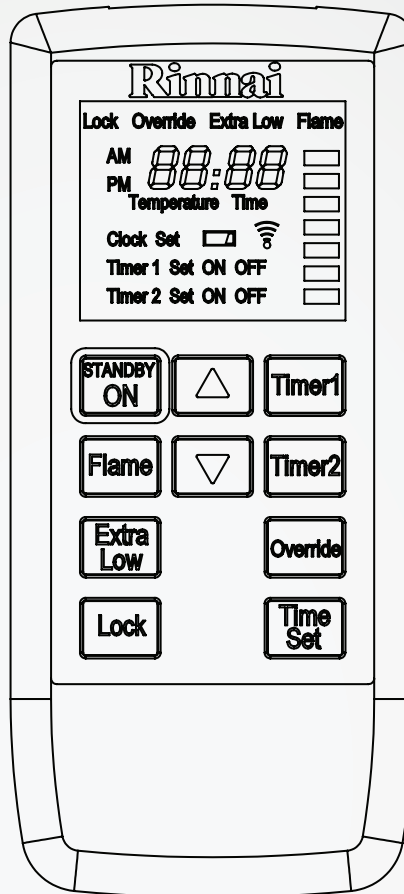

## Standby/On

Stops and operates the heater remotely.

## Flame

Sets the flame picture.

## Extra low

Energy saving room temperature control.

## Lock

Locks out control to prevent tampering.

## Timer 1

Sets timer program 1.

## Timer 2

Sets timer program 2.

## Override

Manually overrides current timer operation.

## Time Set

Sets clock and timers.

After battery replacement the clock and timers may need to be reprogrammed.

## Turning the heater on

When the heater is in standby mode, pressing the Standby/On button will start the ignition sequence and the LED will glow red to indicate that the heater is operating.

## Turning the heater to standby

Press the Standby/On button. This will turn off the unit and the LED will glow green to indicate the appliance is in standby.

## Adjusting the temperature

Pressing the up and down buttons will change the preset temperature by increments of 1 °C—the temperature will be displayed on the remote.

The temperature can be preset to:

- L (low) - continuous combustion on low
- 16~26 °C (in 1 °C) steps - combustion rate varies to maintain the selected temperature
- H (high) - continuous combustion on high

## Setting the clock

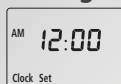

The clock must be set before the timers will operate.

1. Press the Time Set button once, 'Clock Set' will be displayed to confirm the function is initiated. The remote will show 'AM 12:00'.
2. Use the up and down buttons to set AM or PM, then press the Time Set button once to start programming the timers.

If you do not want to set the timers at this point press Time Set four more times until the display returns to the time. If no button is pressed within approximately 90 seconds, the screen will deactivate and any settings that have not been transmitted will be lost.

## Setting the timers

After the clock has been set and the Time Set button selected:

1. 'Timer 1 Set On' and 'AM 06:00' will be displayed. Use the up and down buttons to set the desired AM or PM. Press the Time Set button once.



2. 'Timer 1 Set Off' and 'AM 09:00' will be displayed. Use the up and down buttons to set the desired AM or PM. Press the Time Set button once.

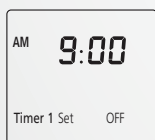

3. To set up Timer 2 repeat the above steps, or press Time Set three times to exit the timer programme.
4. The set On/Off timers will be displayed briefly to confirm the settings. When the programs have been received, the remote display will revert to the time mode.

## Using the timers

Prior to using the timers ensure the desired temperature has been set—refer 'Adjusting the temperature' on the previous page.

You can view the timer settings by pressing the Timer 1 or Timer 2 buttons while the heater is operating. The display will briefly show the status of each timer, i.e. Timer 1 On, Timer 1 Off. If the current time is outside of the programmed times the heater will go into standby mode and the LED will glow green.

To turn the timers off, press the relevant timer button again. The heater will return to standby mode. If there are no timers set the Timer indicator will go out.

## Preheat

The preheat automatically functions in conjunction with the timers. The preheat function ensures the room reaches the desired temperature by the programmed on time. This is achieved by sensing the room temperature one hour prior to start.

## Override

This is used to manually override the timers so the heater can be operated outside of the timer settings. When override is selected 'Override' will be displayed. While in override mode all remote control functions, except for the flame function are available until the next timer setting is reached.

To return to the timer setting, press the Override button a second time. If Standby/On is pressed during override the heater will revert to standby and the timer programs will be cancelled.

## Extra low

The Extra Low function is useful in situations when the room temperature keeps rising even when the heater is on the lowest heat setting.

## Extra low function off

When the room temperature reaches the preset temperature, the heater continues to operate with the main burner on low to provide a flame picture with minimal heat output. In some cases this may still cause the room to become warmer than desired.

## Extra low function on

When the room temperature exceeds the preset temperature, the burner will reduce to an extra low setting. The burner will return to normal to maintain the set temperature.

## Flame

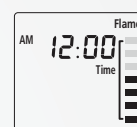

The flame function can be used approximately 90 seconds after heater has started. The

flame function is used to select a desired flame picture and overrides the automatic mode. There are seven flame settings available.

While the heater is in operation, press the Flame button. The heater will automatically default to the last flame picture setting. The word 'Flame' and a series of short bars will be displayed to show the flame function is in operation. Use the up and down buttons to select the desired flame picture. The number of bars illuminated will correspond to your selection.

Should the room temperature exceed 40 °C while the flame function is activated, the heater will switch off—this is a safety feature.

## Lock

This is designed as a child lock function. When Lock is pressed all remote functions will be locked, with the exception of the Standby/On button (for the purpose of turning the heater to standby only). The remote will show 'Lock'. To cancel press the Lock button for three seconds.

# Care of your Arriva 752

Your heater needs very little maintenance, however the following information will keep it looking good and working efficiently.

## Important

Switch off the appliance before cleaning, DO NOT attempt to clean the heater while it is operating or hot.

DO NOT use solvents, all parts of the heater and remote can be cleaned using a soft damp cloth and mild detergent.

## About the filters

The filters of this appliance are located inside the room air return doors (side louvres) and consist of two metal mesh strips.

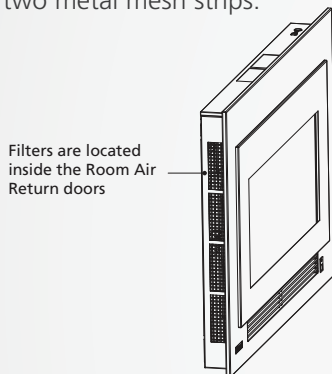

The build up of dust on the filters reduce air flow through to the heater. This reduces the heater's efficiency and can lead to the appliance shutting down. Regular filter cleaning during the heating season will stop this from happening.

## Cleaning the filters

Clean any dust or debris from both sides of the filters using a vacuum cleaner, a soft dry cloth, or a soft brush. NEVER attempt to clean the filters with water.

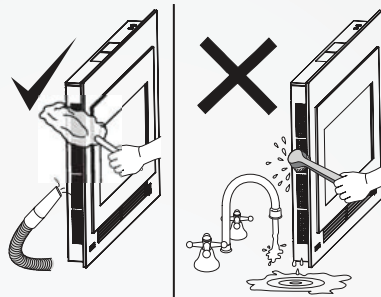

## Heater shutdown due to filter blockages

Do not wait for the blockage indicator (error code 14) to come on before cleaning the filters. Do not continue to use the heater once this indicator is flashing red.

When a build up is detected the blockage indicator LED, located above the receiver window, will begin to flash red to let you know there is a problem.

Once the indicator light is flashing, if no action is taken, the heater will eventually shut down to avoid overheating. Error code 14 will be displayed in the error display window on the control panel of the unit.

## Returning the appliance to normal after a shutdown

To restore normal operation after a filter blockage:

1. Press the On/Off button once to turn off the heater.
2. Clean the filters.
3. Press the On/Off button to turn the heater back on.
4. Use remote control to resume normal operation.

## Lower louvres

It is important that the warm air discharge louvres are kept clear of any obstructions as this will affect the performance of the heater.

When an obstruction is detected the blockage indicator LED (above receiver window) will go red and the heater will turn down to low operation (front burner only). To restore normal operation, remove the obstruction and use the remote control to resume normal heater operation.

# Maintenance and servicing

All external surfaces of the heater can be cleaned using a soft damp cloth and mild detergent. Do not use solvents and do not attempt to clean the heater while it is hot or operating.



Rinnai has a maintenance/service and spare parts network with personnel who are fully trained and

equipped to give the best advice on your Rinnai appliance. Servicing and repair should only be carried out by authorised personnel.

If your appliance needs maintenance/servicing, please call Rinnai (0800 746 624) from a land line and select option one for a service centre in your area.

For reliable operation Rinnai gas fireplaces should be serviced every two years, including inspection of the flue system. If they are in a particularly dusty environment or subject to excess lint, for example dog hair, or where there are newly laid carpets, then annual servicing would be beneficial.

Regular maintenance/servicing is not covered by the Rinnai warranty.

Do not attempt to carry out any service work other than that mentioned in the troubleshooting section. If you have any other faults or problems, please refer to your installer or call Rinnai.

Arriva 752

# Troubleshooting & error codes

# Troubleshooting

Check the following information before making a service call as some performance characteristics of the Arriva are a normal part of operation. If you are still unsure or concerned after reading this section, please contact Rinnai.

During installation there will be an initial burning in period where some smoke and smell may be experienced. This is a normal part of the operation.

The appliance is fitted with an overheat safety switch. Under overheating conditions this switch will shut off the appliance. If the appliance shuts off repeatedly servicing may be required.

## Using the heater for the first time, or after a long period of non use

Ignition may not occur the first time it is operated due to air in the gas pipes. If ignition does not occur within approximately one minute the appliance will attempt to re-light. If ignition does not occur the unit will switch off automatically. Try operating the heater again if this occurs.

The heater may make noises after ignition or switching off. This is due to the expansion and contraction of the internal components—this is normal. The heater will not ignite if the On/Off button is pressed straight after the heater has turned off. It will take approximately 20 seconds before the unit will switch on again.

Characteristic		Explanation
When turning on	Warm air does not start when the burner lights.	The fan starts automatically after a short delay. This is to allow the appliance to warm up, helping avoid cold draughts.
	Smoke or strange smells are produced when first operating the appliance after installation.	This is caused by grease, oil, or dust within the appliance. This will stop after a short time.
	Sharp clicking noises at ignition, or when the unit thermostat modulates to a lower or higher setting, or shuts down.	This is expansion and contraction of the heat exchanger and is a normal part of operation.
During operation	Clunking noise when the thermostat operates	This is the sound of the gas valve opening and closing to regulate the flow of gas.
When turning off	Fan continues to run after the heater is turned off.	This is to remove residual heat from within the appliance. This stops once the unit cools down.
Other	Steam is discharged from the flue terminal outside.	High efficiency appliances tend to discharge water vapour on cold days—this is normal.
	Heater doesn't start when the Standby/On button is pushed (thermostat on high)	Check the appliance On/Off button is on. Check timer(s). Timer programmes must be turned off or overridden for manual operation.
Timers	Timer(s) do not operate at the set time	They may be inactivated or incorrectly programmed. Check timers are set correctly.
	Timer operates for a short time then cuts out	Room temperature may be higher than the set temperature. Increase set temperature if desired. Turn off the Extra Low button if on.

Probable cause	Fault condition						Possible solution
	No display on remote	No ignition or control panel indicators	Burners fail to ignite	Arriva stops during operation	Smell of gas	Remote control doesn't work	
Not plugged in or turned off	●					●	Plug in power cord or press On/Off button
Mains power failure	●			●			Use power failure reset procedure p. 7
Air in gas pipe when initially installed			●				Installer to purge air from gas supply
Filter obstructed				●			Remove and clean filters
Gas escape					●		Isolate gas supply and contact Rinnai for a Service Centre
Timer set						●	Use override button
Lock set						●	Cancel lock
Gas supply turned off			●	●			Turn gas supply on at the meter or cylinder
Flat batteries	●						Replace batteries in remote control
Remote lock-up due to signal being out of range, incorrectly aimed, or obstructed						●	Press the Standby/On button

# Error codes

The Arriva has self diagnostic electronics that monitor the appliance during start up and operation.

Should a fault occur the heater will shut down. The fault that has caused the shut down will be indicated by a pair of flashing digits in the error display window of the control panel, and a green flashing operation indicator.



Error code	Likely cause	Suggested solution
00	Mains power failure	Reset heater, press the On/Off button twice, or use remote control and press the Standby/On button once for standby mode, press the Standby/On button a second time to turn the heater on.
11	Ignition failure	Check gas supply is turned on, switch heater to standby and then on again. If ignition failure continues a service call will be required.
12	Incomplete combustion	As above.
14	Filter blockage/overheat	Clean filters, if error continues a service call is required.
16	Room overheat	Lower room temperature to below 40 °C.
31	Room temperature sensor faulty	Service call.
32	Overheat temperature sensor faulty	Service call.
33	Overheat temperature sensor faulty	Service call.
53	Spark sensor faulty	Service call.
61	Combustion fan motor faulty	Service call.
71	Solenoids faulty	Service call.
72	Flame detection circuit fault	Service call.
73	Communication error	Service call.



# Abnormal flame pattern

Each Rinnai Flame Fire has a distinct flame pattern. This should look the same every time you start your fire, after an initial warm up period of approximately 20 minutes.

Abnormal flame performance and/or pattern can indicate a problem with your fire, such as blocked gas injectors, or that the burn media has shifted from when the fire was first installed. There are some warning signs that could indicate a problem.

- Unusual smell from the appliance
- Continued difficulty or delay in establishing a flame
- Flame appears either very short or very long
- Flame only burns part way across the burner
- Severe soot building up on the inside of the glass door<sup>1</sup>

If any of the above signs occur, please call Rinnai to discuss.

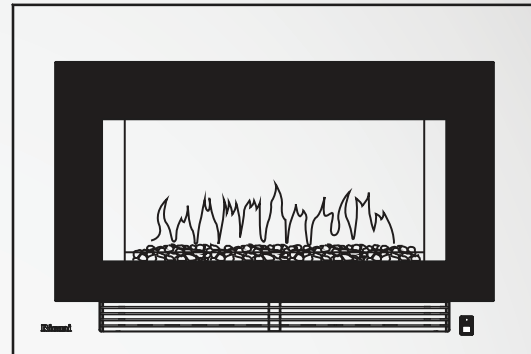

**Normal flame pattern**

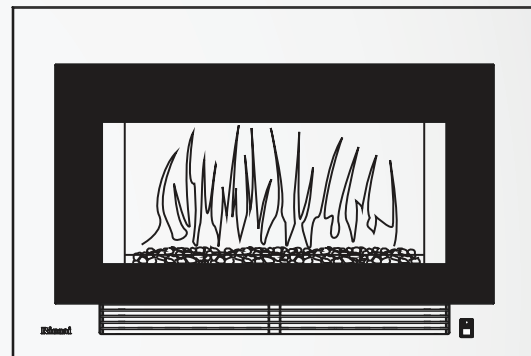

**Abnormal flame pattern**

<sup>1</sup> Appliances incorporating a live fuel effect, and designed to operate with luminous flames, may exhibit slight carbon deposits—this is normal.

# Installation checklist

The installer must complete the installation checklist below and make sure this guide is left with you. They must also instruct you about the use and care of the appliance, and ensure you understand the safety instructions and operation of the appliance.

## Checklist

- Appliance positioned in a suitable location (clearances, mantels, surrounds etc.).
- Rinnai flue system installed and tested to ensure effective draw.
- Gas pressure checked, set, and down rated (if applicable) according to data plate instructions
- Burn media installed as per instructions.
- Appliance tested for correct operation and to ensure no gas leaks.
- Customer instructed on operating procedure and safety requirements.
- Customer advised to service the heater every two years.

## Installer details

Company name:

---

Installer name:

---

Address:

---

---

Phone:

Mobile:

---

Certificate of compliance number for installation:

---

Signed:

Date:

---

# Limited Warranty

Rinnai brings you peace of mind with a:

## 2 Year minimum warranty

### Terms and conditions

1. During the 24 month period from date of purchase and subject to clauses 2 and 3 below, Rinnai New Zealand Limited ("Rinnai") will, at its own discretion, either replace or repair any defective product at no charge to the customer.
2. This warranty covers manufacturing defects only. This warranty will not apply if (for example) the product has been improperly installed or is otherwise installed contrary to manufacturer's recommendations, has been damaged during or after installation, has not been operated in accordance with operating

instructions, or has been subjected to damage or abuse beyond that expected from conditions of normal use.

3. Warranty claims may be invalid if not accompanied by details of the installing or supervising gas fitter's registration number and the gas fitting certification number.
4. This warranty commences from the date of purchase. Proof of purchase is required at the time of any warranty claim.
5. Servicing of the product is to be carried out by a Rinnai authorised service centre.

All Rinnai appliances meet or exceed the safety standards required by New Zealand gas and electrical regulations. The company is constantly improving its products and as such specifications are subject to change or variation without notice.

RECORD YOUR DETAILS  
OF PURCHASE BELOW:

Retailer:

---

Retailer address:

---

---

Date of purchase:

---

Product details:

---

---

---

---

ATTACH YOUR PROOF OF  
PURCHASE HERE:



Please keep these details in a safe place for future reference.



Experience our innovation

**Rinnai.co.nz | 0800 746 624**

<https://www.youtube.com/rinnainz>